

CC404



Security Systems

EN

Operators Guide
Solution 844

BOSCH

Copyright Notice

Unless otherwise indicated, this publication is the copyright of Bosch Security Systems Pty Ltd (“**Bosch**”). All rights are reserved.

You may download a single copy of this publication. By downloading the publication you agree that you will: (i) only use the publication for your own reference; (ii) not commercially exploit or charge any person for the use of the publication; and (iii) not modify the publication in any way without the prior written permission of Bosch.

Except as specified above or where authorised by the Copyright Act 1968 (Cth), no part of this publication may be reproduced, transmitted, modified or stored, in any form or by any means, without the prior written permission of Bosch.

Notice of Liability

This material is designed for use by tradespeople with expertise in the installation of this product. Persons without appropriate expertise should seek assistance before attempting installation.

While care was taken in the preparation of this material, Bosch Security Systems Pty Ltd and its representatives are not responsible to any person or entity for any loss or damage directly or indirectly caused by information in, or any omission from, this material.

Bosch Security Systems Pty Ltd reserves the right to make changes to features and specifications of its products at any time without prior notification.

New Zealand Telepermit Notes

The grant of a telepermit for a device in no way indicates Telecom acceptance of responsibility for the correct operation of that device under all operating conditions.

This equipment will not be used in any manner that could constitute a nuisance to other telecom customers.

Immediately disconnect this equipment should it become physically damaged and arrange for its disposal or repair.

The transmit level from this device is set at a fixed level and because of this, there may be circumstances where the performance is less than optimal. Before reporting such occurrences as faults, please check the line with a standard telepermitted telephone and do not report a fault if the telephone performance is satisfactory.

This device is equipped with pulse dialling while the Telecom standard is DTMF tone dialling. There is no guarantee that Telecom lines will always continue to support pulse dialling.

Use of dialling, when this equipment is connected to the same line as other equipment, may give rise to bell noise and also cause a false answer condition. Should such problems occur, the user should **not** contact the Telecom Faults Service.

This equipment is set up to carry out test calls at pre-determined times. Such test calls interrupt any other calls that may be set up on the line at the same time. The timing set for such test calls should be discussed with the installer.

The timing set for test calls from this equipment may be subject to drift. If this proves to be inconvenient and your calls are interrupted, then the problem of timing should be discussed with the equipment installer. The matter should **not** be reported as a fault to Telecom Faults Service.

This equipment shall not be set up to make automatic calls to the Telecom 111 Emergency Service.

This equipment should not be used under any circumstances that may constitute a nuisance to other Telecom customers.

In the event of any problem with this device, the systems battery, AC mains supply, and telephone line should be disconnected. The user is to arrange with the supplier of the device to make the necessary repairs.

Should the matter be reported to Telecom as a wiring fault and the fault proven to be due to this product, a call-out charge will be incurred.

1.0 Introduction

Congratulations on selecting the Solution 844 Model CC404 Control Panel to protect you and your property. To get the most from your unit, read through this manual and familiarise yourself with the operating features of this system. In all aspects of planning, engineering, styling, operation, convenience, and adaptability, we have sought to anticipate your every possible requirement.

Programming simplicity and speed were some of the major considerations and we believe that our objectives in this area were more than satisfied.

This guide explains all aspects of operating the control panel. All system parameters and options are detailed. Suitability is left up to the individual. Every system can be tailored to meet all requirements quickly and easily.

2.0 Features

The Solution 844 Control Panel uses the latest in microprocessor technology to provide you with more useful features, and superior reliability and performance. The main features of the control panel are:

- Eight programmable User Codes
- STAY Mode and AWAY Mode operation
- Four programmable burglary zones
- Four programmable 24-hour zones
- Siren and/or dialler lockout per zone
- Delayed reporting
- Built-in telephone fail monitor
- Day alarm
- Remote arming
- Answering machine bypass
- Event memory recall
- Upload/download programmable
- Auxiliary output (Output 2)
- Relay output
- Eight radio remote user codes
- Entry and exit warning beeper
- EDMSAT – satellite siren compatible
- Separate fire alarm sound
- Dual reporting
- Sensor watch
- Dynamic battery testing
- Automatic arming and disarming
- AC fail and system fault indicators
- Walk Test Mode
- Monitored siren output (Output 1)
- Strobe output
- Telco arm and disarm sequence (call forwarding)

3.0 Codepad Indicators

Figure 1: CP5 Eight Zone LED Codepad

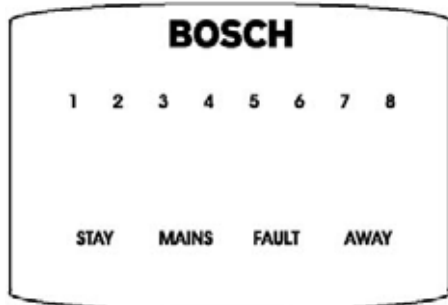
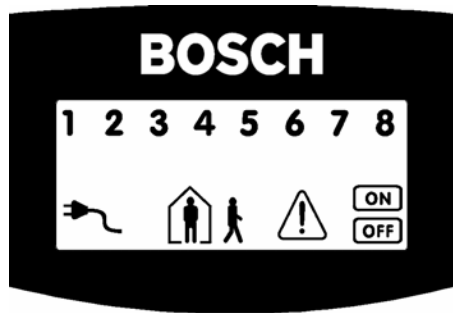

Figure 2: CP5 Eight Zone LCD Codepad



The codepad is the communications interface between you and your alarm system. Use the codepad to issue commands. The codepad offers both visual and audible indications that guide you through general operation.

The codepad incorporates a number of indicators. Eight zone indicators show the status of each zone and four other indicators show general status.

3.1 Zone Indicators

1 2 3 The zone indicators (1 to 8) display the status of the zones. *Table 1* lists the status that the indicators display (such as, Zone Sealed/Zone Unsealed).

Table 1: Zone Indicators

Status	Definition
On	Zone is unsealed.
Off	Zone is sealed.
Flashing fast (0.25 sec on/0.25 sec off)	Zone is in alarm.
Flashing slow (1 sec on/1 sec off)	Zone is manually isolated or selected to be isolated.

3.2 AWAY Indicator



The AWAY indicator shows the system is armed in AWAY Mode. The AWAY indicator also flashes in unison with the STAY indicator when programming the control panel.

Refer to *Section 4.1 Arming in AWAY Mode* on page 7 for information on the different methods of arming the system in AWAY Mode.

Table 2: AWAY Indicator

Status	Definition
On	System is armed in AWAY Mode.
Off	System is not armed in AWAY Mode.

3.3 STAY Indicator



The STAY indicator shows the system is armed in STAY Mode 1 or STAY Mode 2. The STAY indicator also flashes in unison with the AWAY indicator when programming the control panel.

Refer to *Section 4.2 Arming in STAY Mode 1* on page 7 and *Section 4.3 Arming in STAY Mode 2* on page 7.

Table 3: STAY Indicator

Status	Definition
On	System is armed in STAY Mode 1 or STAY Mode 2.
Off	System is not armed in STAY Mode 1 or STAY Mode 2.
Flashing twice a second	Zone Isolating Mode or setting STAY Mode 2 zones.
Flashing once every 3 seconds	Day alarm status – day alarm turned on.

3.4 System Disarmed



This indicator and the **OFF** indicator light when the system is disarmed.

3.5 MAINS Indicator



The MAINS indicator shows if the systems AC mains supply is normal or failed.

Table 4: MAINS Indicator

Status	Definition
On	AC mains power normal.
Flashing	AC mains supply failed.

3.6 Off Indicator/Zone Sealed



The **OFF** indicator lights when the system is disarmed and flashes when a zone becomes unsealed when disarmed. The indicator stops flashing when all zones are sealed.

3.7 On Indicator/Zone in Alarm



The **ON** indicator lights when the system is armed in AWAY Mode and flashes when an alarm occurs. The system resets this indicator after you enter a valid user code.

3.8 FAULT Indicator



The FAULT indicator lights if the system detects a system fault. Refer to *Section 11.0 Fault Analysis Mode* on page 11 for additional information on system faults.

Every time a new system fault is detected (the FAULT indicator flashes), the codepad beeps once every minute. Pressing [#] once cancels the once a minute beep and acknowledges the fault (the FAULT indicator lights steadily).

Table 5: FAULT Indicator

Indicator	Definition
On	There is a system fault you must correct.
Off	The system is normal. There are no faults.
Flashing	There is a system fault that must be acknowledged.

3.9 Audible Indications

Table 6 defines the audible indicators generated by the codepad buzzer.

Table 6: Audible Indicators

Indicator	Definition
One short beep	A button was pressed on the codepad, or end of exit time occurred when armed in STAY Mode 1 or STAY Mode 2.
Two short beeps	The system accepted your code.
Three short beeps	The system executed the requested function.
One long beep	Indicates the end of exit time when armed in AWAY Mode, or the requested operation was denied or aborted.
One beep every second	Walk Test Mode is currently active or it is a warning before automatic arming takes place.
One short beep every minute	There is a system fault waiting to be acknowledged.

4.0 Arming the System

There are several ways to arm the system depending on whether you are:

- Leaving the premises and you want all active zones to be in a ready state for an intruder.
- Remaining in the premises and you only want part of the system to be in a ready state for an intruder.

If a zone is not sealed at the end of exit time, the zone is automatically isolated and lights steadily on the remote codepad. The zone becomes an active part of the system when the zone is resealed. For example, if a window is left open after exit time expires, the window is not an active part of the system until the window is closed. Opening the window after exit time expires causes an alarm.

Table 7 defines the different methods for arming the system.

Table 7: Arming Methods

Method	Definition
AWAY Mode	Arms the entire system. Refer to <i>Section 4.1 Arming in AWAY Mode</i> .
STAY Mode 1	Arms all zones except those programmed by the installer to be automatically isolated. Refer to <i>Section 4.2 Arming in STAY Mode 1</i> .
STAY Mode 2	Arms all zones except those programmed by the Master Code holder to be automatically isolated. Refer to <i>Section 4.3 Arming in STAY Mode 2</i> .

Forced Arming

Arming the system when a zone is not sealed is known as forced arming. If the system is not armed and a long beep sounds, forced arming is not permitted. If this is the case, ensure that all zones are sealed or manually isolated before arming the system.

4.1 Arming in AWAY Mode

When you leave your premises and require all zones to be in a ready state to detect intrusion, arm the system in AWAY Mode. When returning to your premises, disarm your system (see *Section 5.0 Disarming the System*) so you do not sound a false alarm.

There are two different methods for arming the system in AWAY Mode. One method is standard and is always available. The other method is optional and might be disabled by your installer.

To arm in AWAY Mode using the first method:

Enter your user code and press [#] (for example, [2 5 8 0 #]). Two beeps sound and the AWAY indicator lights. Exit time starts.

To arm in AWAY Mode using the second method:

Hold down [#] until two beeps sound. The AWAY indicator lights and exit time starts.

4.2 Arming in STAY Mode 1

STAY Mode 1 is only used when the perimeter and unused areas of the premises must be armed to detect if an intruder is entering the premises. At the same time, it allows you to move freely within an area that is automatically isolated.



Only your security company can program zones automatically isolated in STAY Mode 1.

There are two different methods for arming the system in STAY Mode 1. One method is standard and is always available. The other method is optional and might be disabled by your installer.

Entry Guard Timer for STAY Mode 1

When arming the system in STAY Mode 1, an optional entry timer called Entry Guard Timer for STAY Mode 1 is available. Use this entry timer to delay the sirens if a zone is not automatically isolated and activates an alarm. Entry Guard Timer for STAY Mode 1 is the delay time used for all zones except 24-hour zones when the system is armed in STAY Mode 1 or STAY Mode 2.

If the Entry Guard Timer for STAY Mode 1 is programmed and a zone not automatically isolated is activated, the codepad beeps twice per second until the entry timer expires or the system is disarmed. If the alarm condition is not reset by entering your user code and pressing [#] (for example, [2 5 8 0 #]) before the entry timer expires, the sirens sound an alarm. Only your installer can program this feature.

To arm in STAY Mode 1 using the first method:

Enter your user code and press [*] (for example, [2 5 8 0 *]). Two beeps sound and the STAY indicator lights. Exit time starts counting.

Any zones programmed to be automatically isolated in STAY Mode 1 flash until exit time expires. At the end of exit time, all zones selected to be automatically isolated turn off and the codepad gives one short beep.

To arm in STAY Mode 1 using the second method:

Hold down [*] until two beeps sound. The STAY indicator lights and exit time starts.

Any zones programmed to be automatically isolated in STAY Mode 1 flash until exit time expires. At the end of exit time, the zone indicators turn off and the codepad sounds one short beep.

4.3 Arming in STAY Mode 2

STAY Mode 2 is used only when you want to arm the perimeter and unused areas of the premises to detect an intruder while you move freely within an automatically isolated area. Any Master Code user can program zones to be automatically isolated in STAY Mode 2.

Entry Guard Timer for STAY Mode 2

When arming the system in STAY Mode 2, an optional entry timer called Entry Guard Timer for STAY Mode 2 is available. Use this entry timer to delay the sirens if a zone is not automatically isolated, but activates an alarm. Entry Guard Timer for STAY Mode 2 is the delay time used for all zones, except 24-hour zones, when the system is armed in STAY Mode 1 or STAY Mode 2.

If the Entry Guard Timer for STAY Mode 2 is programmed and a zone not automatically isolated activates an alarm, the codepad beeps twice a second until the entry timer expires or you disarm the system. If you do not reset the alarm by entering your user code and pressing [#] (for example, [2 5 8 0 #]) before the entry timer expires, the system activates the sirens to sound an alarm. Only your installer can program this option.

To arm in STAY Mode 2:

Hold down [0] until two beeps sound.
The STAY indicator lights and exit time starts.

Any zones programmed to be automatically isolated in STAY Mode 2 flash until exit time expires. At the end of exit time, the indicators turn off for all zones selected to be automatically isolated and the codepad sounds one short beep.

4.4 Programming STAY Mode 2 Zones

If you have a Master Code, you can only program zones to be automatically isolated in STAY Mode 2.

How to Program STAY Mode 2 Zones

1. Enter your four-character Master Code and press [4 #] key (for example, [2 5 8 0 4 #]).
Three beeps sound and the STAY indicator flashes.
2. Enter the zone number to automatically isolate and press [*] (for example, [1 *] for Zone 1 or [2 *] for Zone 2).
The selected zone flashes.
If you make a mistake, enter the same zone number and press [#] to clear the incorrect zone.
To select additional zones to automatically isolate in STAY Mode 2, repeat Step 2 as many times as necessary.
3. After you select the zones to automatically isolate in STAY Mode 2, press [#] to exit this mode.
Two beeps sound and the STAY and AWAY indicators turn dark.

5.0 Disarming the System

When you enter the premises after the system is armed in AWAY Mode, or if you armed the system in STAY Mode 1 or STAY Mode 2, you must disarm the system before entry time expires to disable detection devices that activate an alarm. Only your installer can program the entry time.

If there was an alarm before you disarm the system, a flashing zone indicator shows a previous alarm on that zone.

To disarm the system:

Enter your user code and press [#] key (for example, [2 5 8 0 #]).
Two beeps sound.

6.0 User Codes**6.1 Adding User Codes**

Only the Master Code holder can add or change other system user codes, including the Master Code. The Master Code holder can program up to eight user codes for the system.

To add a user code:

1. Enter your four-character Master Code and press [1 #] (for example, [2 5 8 0 1 #]).
Three beeps sound and the STAY and AWAY indicators flash.
2. Enter the user code number (1 to 8) and press [#] (for example, [2 #] for User 2, or [8 #] for User 8).
Two beeps sound and the selected user number appears on the codepad indicators.
3. Enter the digits required for the new code and press [#] (for example, for user code 5768, enter [5 7 6 8 #]).
Two beeps sound and the STAY and AWAY indicators turn off.
To add or change other user codes, repeat this procedure as many times as necessary.

6.2 Adding Radio Remote User Codes

Only the Master Code holder can add or change other system user codes, including the Master Code. The Master Code holder can program up to eight radio user codes (User Codes 9 to 16) for the system.

To add a radio remote user code:

1. Enter your four-character Master Code and press [1 #] (for example, [2 5 8 0 1 #]).
Three beeps sound and the STAY and AWAY indicators flash.
2. Enter the radio remote user code number (9 to 16) and press [#] (for example, [9 #] for User 9, or [1 6 #] for User 16).
Two beeps sound and the selected user number appears on the codepad indicators.
3. Press any button on the keyfob so the system learns the ID number. Two beeps sound and the STAY and AWAY indicators turn off.
To add or change other radio remote user codes, repeat this procedure as many times as required.

6.3 Deleting User Codes/Radio User Codes

Only the Master Code holder can delete other system user codes.

To delete a user code:

1. Enter your four-character Master Code and press [1 #] (for example, [2 5 8 0 1 #]).
Three beeps sound and the STAY and AWAY indicators flash.
2. Enter the user code number (User Code 1 to 8, or Radio User Code 9 to 16) and press [#] (for example, [2 #] for User 2, [1 6 #] for User 16).
Two beeps sound and the selected user number appears on the codepad indicators.
3. Press the [*] key to delete the selected user code.
Two beeps sound and the STAY and AWAY indicators turn off. To delete other user codes, repeat this procedure as many times as required.

7.0 Radio Transmitter Operations

Figure 3: RE012E – 2 Channel Keyfob Transmitter

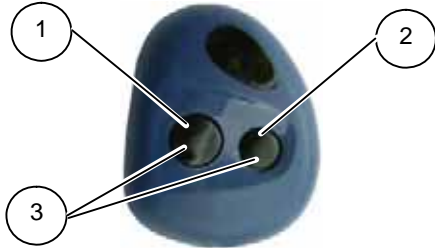

- 1 – Button 1: Arm or disarm in AWAY Mode
- 2 – Button 2: Arm or disarm STAY Mode
- 3 – Buttons 1 and 2: Press both buttons at the same time to activate Panic alarm.

Figure 4: RE013E – 4 Channel Keyfob Transmitter

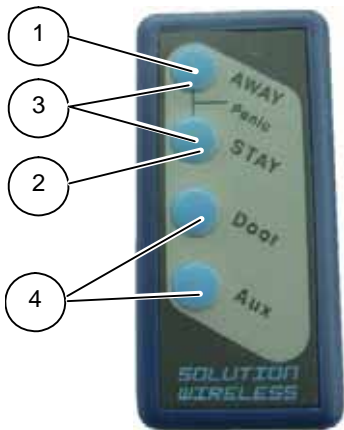

- 1 – Button 1: Arm or disarm in AWAY Mode
- 2 – Button 2: Arm or disarm in STAY Mode
- 3 – Buttons 1 and 2: Press both buttons at the same time to activate Panic alarm.
- 4 – Buttons 3 and 4: Your security company can program these buttons for optional operation, such as operating a garage door.

Audible and Visual Indications

When using hand-held keyfob transmitters to operate the system, your security company can program the keyfobs to sound the horn speaker or operate the blue strobe light. These indications allow you to operate the system from outside the premises with confidence.

Table 8: Keyfob Audible and Visual Indications

Indication	Definition
One beep	System disarmed.
Two beeps	System armed in AWAY Mode.
Two-tone beep	System armed in STAY Mode.
3-sec strobe	System disarmed.
6-sec strobe	System armed in AWAY or STAY Mode.

8.0 Alarms

8.1 Duress Alarm

A codepad duress alarm is used as a silent hold-up alarm. This only occurs when a user adds 9 to the end of a valid user code when disarming the system (for example, [2 5 8 0 9 #]). A duress alarm is only useful if your system reports back to a monitoring station or pocket pager, because domestic reporting (such as a mobile phone) cannot decipher which type of alarm occurred.

Figure 5: CP5 LED Codepad Showing Audible Alarm Buttons

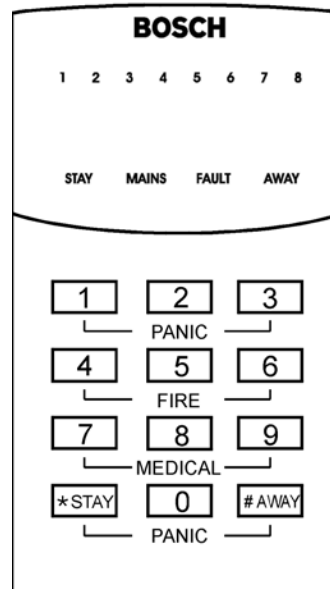

8.2 Panic Alarm

An audible alarm activates when you press [1] and [3] or [*] and [#] simultaneously. Contact your installer to disable the ability to activate the codepad panic alarm or to silence the codepad panic alarm.

8.3 Fire Alarm

The horn speaker emits a distinct fire sound when you press [4] and [6] simultaneously. Contact your installer to disable the ability to activate the codepad fire alarm or to silence the codepad fire alarm.

8.4 Medical Alarm

An audible alarm activates when you press [7] and [9] simultaneously. Contact your installer to disable the ability to activate the codepad medical alarm or to silence codepad medical alarm.

8.5 Tamper Alarm (Access Denied)

The tamper alarm restricts the number of times someone can attempt to use an invalid user code to operate the system. When the number of incorrect code attempts equals the number programmed by your installer, the system activates an alarm. If reporting back to a security monitoring station, the system sends an Access Denied Report.

To shut down and lock out a codepad for a period of time (0 to 150 seconds), ask your installer to program this feature.

9.0 Isolating Zones

Isolating zones allow you to manually disable one or more zones before arming the system. Once a zone is isolated, you can access that zone during the armed state without activating an alarm.

For example, you might need to isolate a zone because before arming the system a PIR detector might generate a false alarm, or you need to leave a pet inside a particular zone while away.

Isolating zones is performed by one of two methods. The second method is optional and only allows those user codes programmed by your installer access to isolate zones.

9.1 Standard Isolating

Standard isolating allows all operators to isolate zones without knowing a valid user code.

To isolate a zone:

1. Press [*] twice to enter Isolating Mode. Three beeps sound and the STAY indicator flashes.
2. Enter the zone number (1 to 8) and press [*] (for example, [1 *] for Zone 1, or [2 *] for Zone 2). Each zone to isolate has a corresponding zone indicator that flashes. If you selected an incorrect zone to isolate, enter the incorrect zone number again and press [*]. Repeat *Step 2* if you are isolating more than one zone, until all zones you want to isolate are selected.
3. Press [#] after you isolate all selected zones. Two beeps sound and the system returns to the disarmed state.

9.2 Code to Isolate

Only the user codes with the Code to Isolate priority level can isolate zones. If any user code has this priority level, the standard isolating method (refer to *Section 9.1 Standard Isolating*) does not function.

To isolate a zone:

1. Press [*], enter your user code, and press [*] again to enter Isolating Mode (for example, [* 2 5 8 0 *]). Three beeps sound and the STAY indicator flashes.
2. Enter the zone number (1 to 8) and press [*] (for example, [1 *] for Zone 1 or [2 *] for Zone 2). Each zone to isolate has a corresponding zone indicator that flashes. If you selected an incorrect zone to isolate, enter the incorrect zone number again and press [*]. If you are isolating more than one zone, repeat *Step 2* until you select the zones you want to isolate.
3. Press [#] after all selected zones are isolated. Two beeps sound and the system returns to the disarmed state.

10.0 Setting the Date and Time

Programming the date and time is only required when you need functions such as automatic test reports, automatic arming, and history events to operate correctly.

To program the date and time:

1. Enter your Master Code and press [6 #] (for example, [2 5 8 0 6 #]). Three beeps sound and the STAY and AWAY indicators flash.
2. Enter the day, month, year, hour, and minute using the (DD, MM, YY, HH, MM) format (that is, DD = day of the month, MM = month of the year, YY = current year, HH = hour of the day, MM = minute of the day).



When programming the hour of the day, you must use a 24-hour format.

3. Press [#] to exit and return to the disarmed state. Two beeps sound and the STAY and AWAY indicators turn off. A long beep sounds if you incorrectly entered the date and time.

11.0 Fault Analysis Mode

If a fault occurs, the FAULT or MAINS indicators flash and the codepad beeps once every minute.

11.1 AC Fail

If the AC mains supply fails, the MAINS indicator flashes until the AC mains supply is restored. Pressing [#] once acknowledges the fault and stops the codepad from beeping once every minute.

11.2 System Faults

To determine all system faults other than the AC mains supply, enter Fault Analysis Mode:

1. Hold down [5] until two beeps sound.
The FAULT indicator lights steadily and the STAY and AWAY indicators flash in unison. Any lit zone indicators indicate the type of fault that occurred. See *Table 9* for the list of system faults that can occur.
2. To further determine the type of fault condition, hold down the key that corresponds to the lit zone indicator.
3. To exit Fault Analysis Mode and return to the disarmed state, press [#].
The FAULT indicator remains lit and the codepad stops beeping once per minute.

11.3 Fault Descriptions

Table 9: Fault Condition Indicators

Zone LED	FAULT Condition
1	Battery Fail
2	Date/Time
3	Sensor Watch
4	Horn Speaker Fail
5	Telephone Line Fail
6	E2 Fault
7	Fuse Fail
8	Communication Fail

Battery Fail

A battery fail fault registers when the system detects a low capacity backup battery. The system automatically performs a Battery Test every 4 hours and every time the system is armed.

Date and Time

The date and time fault registers every time the system powers down. This type of fault does not cause the FAULT indicator to display on the codepad unless your installer programmed the automatic arming time. Refer to *Section 10.0 Setting the Date and Time* to program the date and time.

Sensor Watch Fail

A sensor watch fault registers because one or more detection devices failed to notice any movement during the disarmed state for the time period programmed by your installer. The fault clears when the zone in question detects movement and is reset.

While in Fault Analysis Mode, hold down [5] until two beeps sound.

The indicator corresponding to the faulted zone lights.

Horn Speaker Fail

A horn speaker failure fault registers when the system detects the horn speaker is disconnected. This fault clears once the horn speaker is reconnected. Your installer must program the system for this feature to operate.

Telephone Line Fail

A telephone line failure fault registers when the system detects the telephone line is disconnected from the control panel. Your installer must program the system for this feature to operate.

E2 Fault

An E2 failure fault registers when the system detects an internal checksum error. Contact your installer if this fault occurs.

Fuse Fail

A fuse failure fault occurs when either of the two 1 A fuses are blown. Contact your installer if this fault occurs.

Communication Fail

A communication fail fault registers when the control panel fails to communicate with the receiving party (for example, a monitoring company, mobile phone, pocket pager, and so on). The communication fault clears after the control panel successfully reports to the receiving party.

12.0 Telco Arm/Disarm Sequence (Call Forward On/Off)

12.1 Telco Arm Sequence

Use this section to program the Call Forward – Immediate On sequence or Call Forward – No Answer sequence to automatically operate when you arm the system in AWAY Mode. This feature is only available if your telecommunications provider has the call-forward option.



The examples given in this feature are only applicable to Australia.

Call Forward – Immediate On

You can redirect calls to anywhere in Australia, including mobile phones, pagers, and answering services. When Call Forward is turned on, your telephone does not ring.

Call Forward – No Answer

If your telephone is not answered within 20 sec, this feature redirects all incoming calls to another number anywhere in Australia. When this feature is enabled, you can still make outgoing calls.

Table 10: Telco Arm/Disarm Dialling Digits

Digit Required	Number to Program	Digit Required	Number to Program
0	0	8	8
1	1	9	9
2	2		
3	3	*	*1
4	4	#	*2
5	5	4-sec pause	*3
6	6	break	*4
7	7		

To program the Telco Arm Sequence:

1. Enter your four-character Master Code and press [3 #] (for example, [2 5 8 0 3 #]).
Three beeps sound and the STAY and AWAY indicators flash.
2. Press [1 #] to select the Telco Arm Sequence.
Three beeps sound.
3. Enter the call forward sequence (for example, [* 6 1][Phone Number][#] to program the Call Forward - No Answer sequence, or [* 2 1][Phone Number][#] to program the Call Forward Immediate sequence).
To program a "*" in the Telco Arm Sequence, enter [* 1]. To program a "#" in the Telco Arm Sequence, enter [* 2].

4. Press [#] when finished.
Two beeps sound, and the STAY and AWAY indicators turn off.



To disable the Telco Arm Sequence, enter the call forward sequence as [* 4] (break) for Step 3.

12.2 Telco Disarm Sequence

This feature automatically disables the call forward sequence when disarming the system.

To program the Telco Disarm Sequence:

1. Enter your four-character Master Code and press [3 #] (for example, [2 5 8 0 3 #]).
Three beeps sound and the STAY and AWAY indicators flash.
2. Press [2 #] to select the Telco Disarm Sequence.
Three beeps sound.
3. Enter the call forward disable sequence (for example, [# 6 1 #] to disable the No Answer Call Forward sequence, or [# 2 1 #] to disable the Call Forward Immediate sequence).
To program a "#" in the Telco Disarm Sequence, enter [* 2].
4. Press [#] when finished.
Two beeps sound, and the STAY and AWAY indicators turn off.



To disable the Telco Disarm Sequence, enter the call forward sequence as [* 4] (break) for Step 3.

13.0 Turning Outputs On/Off

This feature only applies if your installer set up an output to be turned on or off by the codepad. Your installer can program up to three outputs to control a pool pump, outside lighting, and so on.

To turn an output on or off:

1. Enter your Master Code and press [5 #] (for example, [2 5 8 0 5 #]).
Three beeps sound and the STAY and AWAY indicators flash.
2. Enter the output number (1 to 3) you want to turn on or off.
3. Press [#] to turn the output on, or press [*] to turn the output off.
Three beeps sound if you turn the output on, and two beeps sound if you turn the output off.
Repeat Step 2 and Step 3 to turn other outputs on or off.
4. Press [#] to exit this function.
Two beeps sound and the STAY and AWAY indicators turn off.

14.0 Reset Latching Outputs

This feature only applies if your installer programmed an output to latch (remain on) until you acknowledge the event that turned on the output.

To reset latching outputs:

Hold down [7] until two beeps sound. The output resets.

15.0 Codepad ID/Buzzer Tone Change

Hold down [8] continuously to change the tone of the codepad buzzer.

There are 50 different tones, from 1500 Hz to 5000 Hz. If multiple codepads are installed, each codepad can sound a different tone.

16.0 Testing

There are five functions for testing that your system operates correctly.

16.1 Horn Speaker Test

Press and hold [1] until two beeps sound.
The horn speaker sounds for 2 sec.

16.2 Bell Test

Press and hold [2] until two beeps sound.
The bell output turns on for 2 sec.

16.3 Strobe Test

1. Press and hold [3] until three beeps sound.
The strobe flashes.
2. Press and hold [3] until two beeps sound.
The strobe stops flashing.

16.4 Walk Test Mode

Use Walk Test Mode to test the proper operation of detection devices. Every time you test a zone, the codepad sounds one long beep and the horn speaker sounds one short beep to indicate the zone was activated when testing.

1. Enter your four-character Master Code and press [7 #] (for example, [2 5 8 0 7 #]).
Three beeps sound, and the STAY and AWAY indicators flash. The codepad beeps once per second while the system is in Walk Test Mode.
2. Activate the zones you want to test.
The codepad sounds one long beep and the horn speaker sounds one short beep each time a zone is faulted (unsealed) and restored.
3. When you finish testing the zones, press [#] to exit this mode.
Two beeps sound, and the STAY and AWAY indicators turn off. The system returns to the disarmed state.

16.5 Test Report

This feature only applies if your system reports by telephone. Press and hold [9] until two beeps sound.
The system sends a Test Report without sounding the sirens.

17.0 Event Memory Recall

Use this function to replay the last 40 system events that occurred. The event memory history replays all alarms, and arming and disarming of the system in AWAY Mode, STAY Mode 1, and STAY Mode 2.



The system cannot differentiate between arming the system in STAY Mode 1 or STAY Mode 2.

To enter Event Memory:

Enter your four-character Master Code and press [8 #] (for example, [2 5 8 0 8 #]). Three beeps sound. The last 40 events appear one at a time by the codepad indicators, starting from the most recent event. A beep sounds as each event appears.

18.0 Day Alarm

Day alarm allows the system to monitor a combination of zones when the system is disarmed by beeping the codepad buzzer. Only your installer can program Zones 1 to 4 to operate for day alarm.

Example

You can set up a day alarm at the front door of a shop with a pressure mat or electronic beam that customers activate as they enter and exit the shop. As the customers walk onto the pressure mat or break the electronic beam, the codepad buzzer beeps.

To turn day alarm on:

Hold down [4] until three beeps sound. Day alarm turns on. If a zone programmed for day alarm operation is activated when the system is disarmed, the codepad beeps.

To turn day alarm off

Hold down [4] until two beeps sound. Day alarm turns off.

19.0 Remote Arming By Telephone

Use this feature to arm your system by telephone from any remote location. For security reasons, you cannot disarm the system using this method. This feature requires a touch-tone telephone. Remote arming works only if your installer programmed this feature.

To arm your system remotely by telephone:

1. Call the telephone number connected to your control panel.
When the control panel answers the incoming call, a short jingle sounds.
2. To arm the system, press [*] on the touch-tone telephone for 1 to 3 sec.
If you hear modem tones when the control panel answers the incoming call, the system is programmed for remote programming functions by your installer. Wait for a pause between the tones before you press [*].
After you release [*] on the touch-tone telephone, two beeps sound. The system is armed in AWAY Mode.
3. Hang up the telephone.
The system remains armed.



If your installer programmed answering machine bypass, you must call the control panel twice to connect to the system. For example, call the telephone number for the control panel, let the call ring no more than four times, and then hang up the telephone. Wait at least 8 sec and call the control panel again.

20.0 Domestic Dialling

Domestic dialling enables the control panel to call your mobile phone or a relative or friend if the system detects an alarm. You can program up to three different telephone numbers to call when an alarm occurs. Although only your installer can set the system to report in the domestic format, the Master Code holder can change the domestic telephone numbers at any time.

20.1 Acknowledging Domestic Calls

If an alarm occurs, the system calls the first programmed telephone number. When you answer an incoming call, the system sounds a repeating siren tone followed by a pause, continuously for 2 min (for example, siren tone, pause, siren tone, and pause).

If you do not acknowledge the call from the control panel during a pause between siren tones, the control panel hangs up after 2 min, and calls the next telephone number.

Press [*] for 1 to 3 sec during the pause to acknowledge the call.

If you acknowledge the call, the control panel does not call any more phone numbers for that event. If the call is successfully acknowledged, a tone of decreasing pitch sounds.

Table 11: Domestic Dialling Telephone Digits

Digit Required	Number to Program	Digit Required	Number to Program
0	0	8	8
1	1	9	9
2	2		
3	3	*	*1
4	4	#	*2
5	5	4-sec pause	*3
6	6	break	*4
7	7		

20.2 Programming Domestic Telephone Numbers

If your system is configured for domestic dialling, the Master Code holder can program the telephone numbers the control panel calls if an alarm occurs.

To program telephone numbers:

1. Enter your four-character Master Code and press [2 #] (for example, [2 5 8 0 2 #]). Three beeps sound and the STAY and AWAY indicators flash. If there are telephone numbers already programmed, the numbers appear one digit at a time by the codepad indicators. If there are no telephone numbers programmed, another two beeps sound after entering this mode. These two beeps are normally heard after the last digit of the last telephone number appears.
2. Enter the first telephone number (for example, [9 6 7 2 1 7 1 7]). As you enter each digit, the corresponding codepad indicators light.
3. To program another telephone number, press [* 4] and repeat *Step 2*. This inserts a break between the first telephone number and the second telephone number.
4. Press [#] to exit this function.

20.3 Disable Domestic Dialling

To suspend domestic dialling (for example, you are moving and do not want the system to continue calling your mobile phone):

1. Enter your four-character Master Code and press [2 #] (for example, [2 5 8 0 2 #]). Two beeps sound and the STAY and AWAY indicators flash.
2. Press [* 4 #]. The STAY and AWAY indicators turn off.

21.0 Basic Pager Reporting

This feature only applies if your system reports to a pocket pager. Basic pager reporting requires some interpretation of the numbers that appear on the display. It is possible to differentiate between 1000 different systems when a number of control panels report to the one pocket pager.

Subscriber ID Number

This is the identification number of the control panel. Only your installer can program this number.

Zone Status

The zone status display shows the status of each zone (1 to 8). *Table 12* describes each number of the zone status display.

Display	Zone Description
0	Normal. The corresponding zone is sealed.
1	Alarm. The corresponding zone is unsealed and in alarm.
2	Bypassed. A system operator manually isolated the corresponding zone. Refer to <i>Section 9.0 Isolating Zones</i> for information about manually isolating a zone(s) before arming the system.
3	Trouble. A zone was unsealed when exit time expired.

System Status

The system status information is divided into the four digits identified in *Table 13*.

Digit	Description
First	8 = the system is disarmed 9 = the system is armed
Second	Identifies the codepad alarm activated by the operator: 0 = No Codepad Alarm 1 = Codepad Panic or Duress Alarm 2 = Codepad Fire Alarm 3 = Codepad Medical Alarm
Third	0 = AC Supply is normal 1 = AC Supply failed
Fourth	0 = System Normal – There are no faults. 1 = System Fault – The control panel registered a fault.

Figure 6 shows a transmission from a control panel with an ID number of 678, and Zone 2 in alarm.

Figure 6 also shows Zone 3 is manually isolated and the system is armed.

Figure 6: Basic Pager Display

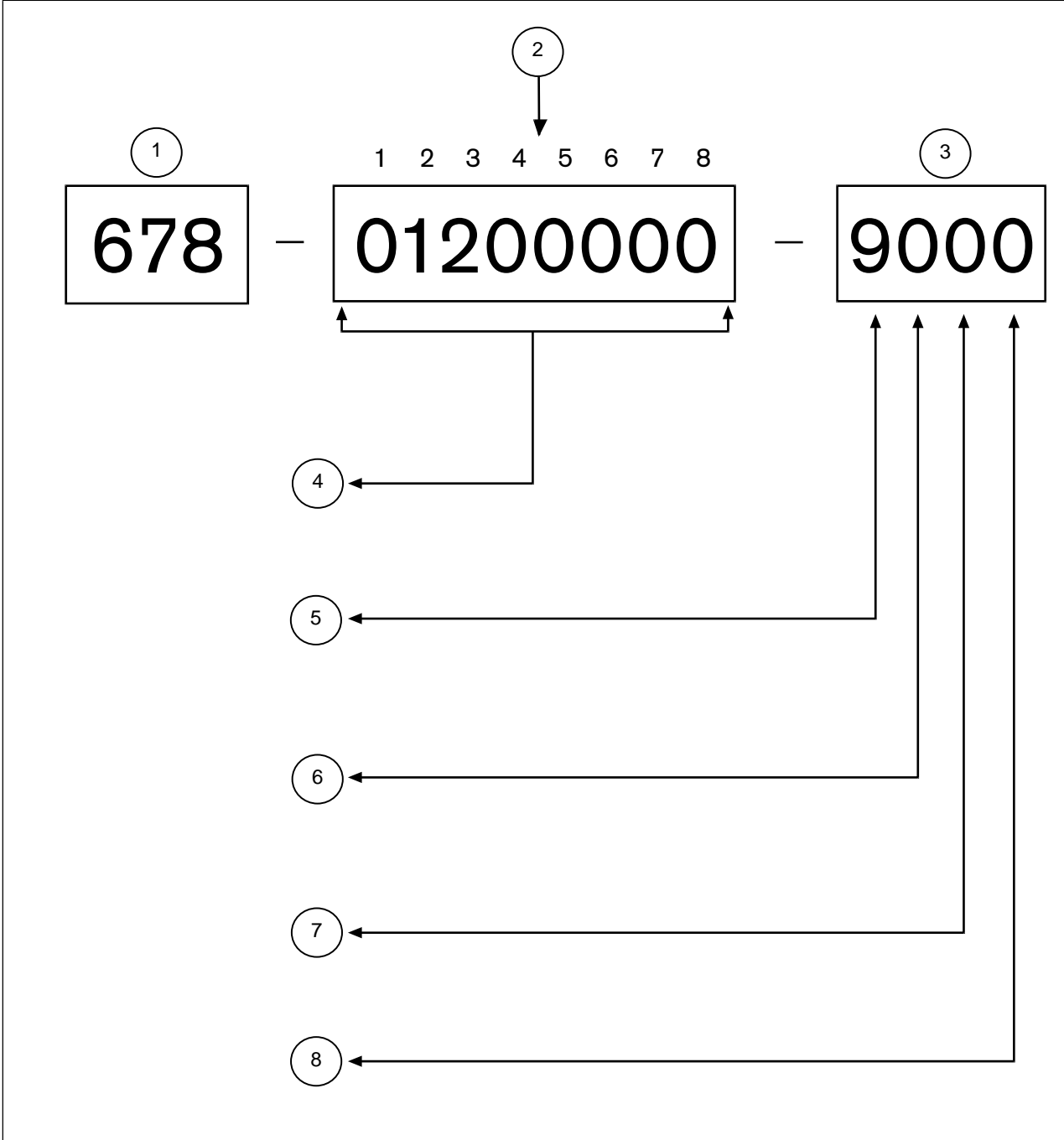

- 1 – Subscriber ID number
- 2 – Zone status
- 3 – System status
- 4 – 0: Zone Normal
1: Alarm
2: Zone Bypassed
3: Zone Trouble
- 5 – 8: Disarmed
9: Armed

- 6 – 0: Normal
1: Panic/Duress
2: Fire Alarm
3: Medical Alarm
- 7 – 0: AC Normal
1: AC Failure
- 8 – 0: System Normal
1: System Fault

22.0 SMS Reporting

SMS Reporting is an optional feature that your installer can add allowing your control panel to send SMS text messages to your mobile phone.

The SMS messages for the possible alarm events are listed in *Table 14*. The <Subscriber ID> text is a number between 0000 and 9999 assigned by your installer.

Table 14: SMS Text Messages	
Alarm Event	SMS Text
Panic	<Subscriber ID> Panic
Test	<Subscriber ID> Test
Closing User x ¹	<Subscriber ID> Close User y ²
Opening User x ¹	<Subscriber ID> Open User y ²
Alarm Zone 1	<Subscriber ID> Alarm Zone 01
Restore Zone 1	<Subscriber ID> Restore Zone 01
Alarm Zone 2	<Subscriber ID> Alarm Zone 02
Restore Zone 2	<Subscriber ID> Restore Zone 02
Alarm Zone 3	<Subscriber ID> Alarm Zone 03
Restore Zone 3	<Subscriber ID> Restore Zone 03
Alarm Zone 4	<Subscriber ID> Alarm Zone 04
Restore Zone 4	<Subscriber ID> Restore Zone 04
Alarm Zone 5	<Subscriber ID> Alarm Zone 05
Restore Zone 5	<Subscriber ID> Restore Zone 05
Alarm Zone 6	<Subscriber ID> Alarm Zone 06
Restore Zone 6	<Subscriber ID> Restore Zone 06
Alarm Zone 7 Fire	<Subscriber ID> Fire Alarm Zone 07
Restore Zone 7 Fire	<Subscriber ID> Fire Restore Zone 07
Alarm Zone 8 Tamper	<Subscriber ID> Tamper Alarm Zone 08
Restore Zone 8 Tamper	<Subscriber ID> Tamper Restore Zone 08
AC Fail	<Subscriber ID> AC Fail
AC Restore	<Subscriber ID> AC Restore
Medical	<Subscriber ID> Medical Alarm Zone 07
Medical Restore	<Subscriber ID> Medical Restore Zone 07
Fuse Fail	<Subscriber ID> Fuse Fail
Fuse Reset	<Subscriber ID> Fuse Fail
¹ x = 1 to 16	
² y = 01 to 16	

23.0 Glossary of Terms

Table 15: Glossary of Terms

Term	Description
24-Hour Zones	A monitored input programmed to activate an alarm, if violated, if the system is armed or disarmed.
Alarm	Your system is armed and one of the detection devices was violated. A 24-hour zone (such as a smoke detector) can activate an alarm when your system is armed or disarmed.
Answering Machine Bypass	When answering machine bypass is used, you can connect to the system for remote arming operations when there is an answering machine or facsimile machine connected to the same telephone line.
Armed	The system is in a ready state to accept alarms.
Automatic Arming	The system is automatically armed in AWAY Mode or STAY Mode 1 at the same time every day.
Automatic Disarming	The system is automatically disarmed at the same time every day.
AWAY Mode	Used to arm your system when you leave your premises.
Codepad	The device used to arm and disarm the system, and to execute other functions such as adding and deleting system user codes.
Day Alarm	Monitors a combination of zones when the system is disarmed.
Detectors	Devices connected to your system that detect intrusion or fire, and activate an alarm. Some forms of detection devices include passive infrared (PIR), smoke detectors, photoelectric beams, reed switches, and vibration sensors.
Disarmed	A state in which the system does not accept alarms, except from zones programmed for 24-hour operation.
Dynamic Battery Testing	Monitors and tests the condition of your backup battery.
Entry Time or Entry Delay	The time allowed by a zone to disarm the system after you enter your premises.
External Equipment	Any devices connected to your system such as detectors, codepads, and sirens.
Forced Arming	Enables you to arm your system even though one or more zones are unsealed.
Handover Delay	The system is armed and a zone programmed for delay was violated. The delay zone hands over the remaining delay time to a zone programmed as handover. The handover zone does not activate an alarm until the remaining delay time expires. A handover zone acts as an instant zone if it is violated before the delay zone.
Remote Control	Used to remotely operate your system using hand-held transmitters (keyfobs).
Isolating	Manually disable (isolate) one or more zones before arming the system.
Master Code	A code used to arm and disarm the system and to allow access to functions such as adding and deleting user codes.
Monitoring Station	A secure location where a digital receiver monitors a number of alarm systems and deciphers their Alarm Transmission Reports. The station operator can then advise the appropriate authorities to take immediate action.
Panic Alarm	Type of alarm that indicates to the monitoring station there is an emergency situation at your premises.
Sealed	Refers to zone status. If a zone is sealed, the detection device is not violated and the zone indicator is not lit on the codepad.
Sensor Watch	The ability of the control panel to recognise that detection devices might have stopped working or that the view to a PIR detector is blocked (it is unable to detect any movement during the time programmed by your installer).

Table 15: continued

Term	Description
Silent Alarm	Your installer can program zones for silent operation. When the zone programmed for silent operation is violated during the armed period, your alarm system communicates with the monitoring station without sounding the sirens.
STAY Mode 1	The system automatically isolates zones when you arm the system in STAY Mode 1. Only your installer can program zones to be isolated automatically in this mode.
STAY Mode 2	The system automatically isolates zones when you arm the system in STAY Mode 2. Only the Master Code holder can program zones to be isolated automatically in this mode.
Telco Arm Sequence	Telco arming automatically diverts your telephone number to another telephone when the system is armed in AWAY Mode. In Australia, this feature is called "Call Forward".
Telco Disarm Sequence	Telco disarming automatically calls the telephone exchange and does not forward your telephone number.
Unsealed	Refers to zone status. A zone is unsealed when a zone is violated. The corresponding zone indicator lights on the codepad.
User Code	The personal identification number an operator uses to arm and disarm the system.
Zones	A monitored input used to activate an alarm when violated.

Zone Description

Describe each zone and mark the zones that are programmed to be automatically isolated in STAY Mode 1 or are programmed for day alarm operation.

		Isolated In STAY Mode 1	Day Alarm Enabled
Zone 1	_____	<input type="checkbox"/>	<input type="checkbox"/>
Zone 2	_____	<input type="checkbox"/>	<input type="checkbox"/>
Zone 3	_____	<input type="checkbox"/>	<input type="checkbox"/>
Zone 4	_____	<input type="checkbox"/>	<input type="checkbox"/>
Zone 5	_____	<input type="checkbox"/>	
Zone 6	_____	<input type="checkbox"/>	
Zone 7	_____	<input type="checkbox"/>	
Zone 8	_____	<input type="checkbox"/>	

User Code Names

		Master Code	
Default = 2580	User Code 1 _____	<input checked="" type="checkbox"/>	User Code 9 _____
	User Code 2 _____	<input type="checkbox"/>	User Code 10 _____
	User Code 3 _____	<input type="checkbox"/>	User Code 11 _____
	User Code 4 _____	<input type="checkbox"/>	User Code 12 _____
	User Code 5 _____	<input type="checkbox"/>	User Code 13 _____
	User Code 6 _____	<input type="checkbox"/>	User Code 14 _____
	User Code 7 _____	<input type="checkbox"/>	User Code 15 _____
	User Code 8 _____	<input type="checkbox"/>	User Code 16 _____

Entry/Exit Times

Entry Timer 1 _____ Exit Time _____
 Entry Timer 2 _____ Entry Guard Time _____

Arming Options

Single Button Arming YES NO Forced Arming YES NO
 Single Button Disarming YES NO Remote Arming By Telephone YES NO
 Automatic Arming (AWAY Mode) YES NO Automatic Arming Time _____ AM/PM
 Automatic Arming (STAY Mode) YES NO Automatic Disarming Time _____ AM/PM

Output Descriptions

Output 1 _____ Output 3 _____
 Output 2 _____ Output 4 _____

Isolating Method

Standard Isolating YES NO
 Code To Isolate YES NO

Communication Options

Back To Base Reporting YES NO
 Domestic Reporting YES NO Domestic Reporting – Number Of Beeps

Other System Information

Siren Run Time Minutes
 Sensor Watch Time Increments in Days
 Can Your System Be Serviced By Another Technician YES NO If Yes, Installer's Code _____

25.0 Specifications

Table 16: Specifications

Temperature Range	0°C to +45°C (+32°F to +113°F)
Humidity	10% to 95%
Power Source	TF008 Plug Pack – 240 VAC/18 VAC @ 1.3 A
Standby Current	65 mA
Current Draw In Alarm	115 mA
Current Draw In Alarm with Codepad	105 mA
Backup Battery	6 Ah/12 VDC Rechargeable sealed lead acid battery
Dimensions (case, packed in carton)	30.6 cm x 26.2 cm x 8.4 cm (12.1 in. x 10.3 in. x 3.3 in.)
Weight	2.5 kg (5.5 lb)
Supplier Code	N771
New Zealand Telepermit	PTC 211/98/085
Malaysia Approval Number	Pending



The Austel permit issued for this product is subject to the following conditions:
The Solution 844 Model CC404 Control Panel can only be powered by a Bosch Security Systems TF008 Plug Pack (Approval Number Q92128).



Test the sirens, strobe, and zones at weekly intervals. See *Section 16.0 Testing* for further information.

Index

- 24-Hour Zones 18
- A**
- AC Mains Fail 11
 - Adding Radio User Codes 8
 - Adding User Codes 8
 - Alarm Condition 18
 - Alarms
 - Duress 9
 - Fire 9
 - Medical 10
 - Panic 9
 - Tamper (Access Denied) 10
 - Answering Machine Bypass 18
 - Armed 18
 - Arming
 - AWAY Mode 7
 - STAY Mode 1 7
 - STAY Mode 2 7
 - Telephone Arming 14
 - Audible Indications 6
 - Automatic Arming 18
 - Automatic Disarming 18
 - AWAY Indicator 5
 - AWAY Mode 7, 18
- B**
- Battery Fail 11
 - Battery Testing 18
 - Bell Test 13
- C**
- Codepad 18
 - Duress Alarm 9
 - Fire Alarm 9
 - Medical Alarm 10
 - Panic Alarm 9
 - Tamper Alarm 10
 - Codepad Indicators
 - Audible Indications 6
 - AWAY Indicator 5
 - FAULT Indicator 6
 - MAINS Indicator 6
 - Off Indicator 6
 - On Indicator 6
 - STAY Indicator 5
 - System Disarmed 5
 - Zone Indicators 5
 - Communciation Fail 11
- D**
- Date and Time 11
 - Day Alarm 14
 - Deleting Radio User Codes 8
 - Deleting User Codes 8
 - Detectors 18
 - Disarmed 18
 - Disarming 8
 - Domestic Dialling 15
 - Acknowledging Domestic Calls 15
 - Disable 15
 - Programming Domestic Telephone Numbers 15
 - Duress Alarm 9
- E**
- E2 Fault 11
 - Entry Delay/Entry Time 18
 - Entry Guard Timer 7
 - Event Memory Recall 14
 - External Equipment 18
- F**
- Fault Analysis 11
 - Fault Description
 - AC Mains Fail 11
 - Battery Fail 11
 - Date and Time 11
 - E2 Fault 11
 - Fuse Fail 11
 - Horn Speaker Fail 11
 - Sensor Watch Fail 11
 - Telephone Line Fail 11
 - Fault Descriptions 11
 - Communciation Fail 11
 - System Fault 11
 - FAULT Indicator 6
 - Features 4
 - Fire Alarm 9
 - Forced Arming 7, 18
 - Fuse Fail 11
- H**
- Hand Held Remote Control 18
 - Handover Delay 18
 - Horn Speaker Fail 11
 - Horn Speaker Test 13
- I**
- Isolating 18
 - Isolating Zones 10
 - Code to Isolate 10
 - Standard Isolating 10
- M**
- MAINS Indicator 6
 - Master Code 18
 - Medical Alarm 10
 - Monitoring Station 18
- O**
- Off Indicator 6
 - On Indicator 6

P

Pager Reporting 16
 Panic Alarm 9, 18

R

Radio User Codes
 Adding 8
 Deleting 8
 Remote Arming 14
 Remote Control 18

S

Sealed 18
 Sensor Watch 18
 Sensor Watch Fail 11
 Silent Alarm 19
 STAY Indicator 5
 STAY Mode 1 7, 19
 Entry Guard Timer 7
 STAY Mode 2 7, 19
 Entry Guard Timer 7
 Programming Zones 8
 Strobe Test 13
 System Disarmed 5

T

Tamper Alarm 10
 Telco Arm Sequence 12, 19
 Telco Disarm Sequence 19
 Telephone Line Fail 11
 Test Report 13
 Testing
 Bell Test 13
 Horn Speaker Test 13
 Strobe Test 13
 Test Report 13
 Walk Test 13

U

Unsealed 19
 User Codes 19
 Adding 8
 Adding Radio Users 8
 Deleting 8

W

Walk Test 13

Z

Zone Indicators 5
 Zones 19

Notes

Bosch Security Systems
25 Huntingwood Drive
Huntingwood NSW 2148
Australia
Phone: +612 9672 1777
Facsimile: +612 9672 1717

© 2005 Bosch Security Systems

F01U009494B

SKU:920054



Recyclable

BOSCH